

### The advantages:

- ✓ Compact, monobloc;
- ✓ Economical and performant design;
- ✓ Reduced footprint;
- ✓ Easy inline integration;
- ✓ Accessible and mobile
- ✓ Numerous industrial applications.

- **Industrial oven** that integrates a gear mot. turntable, with distinct section to accommodate workparts on one or more levels
  - **Continuous oven**



### Conditions of use

- Max temperature. : < 400 °C

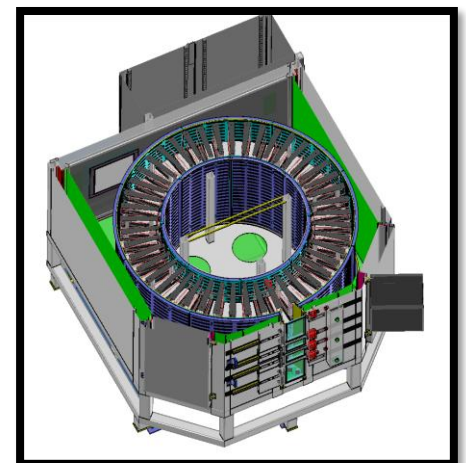
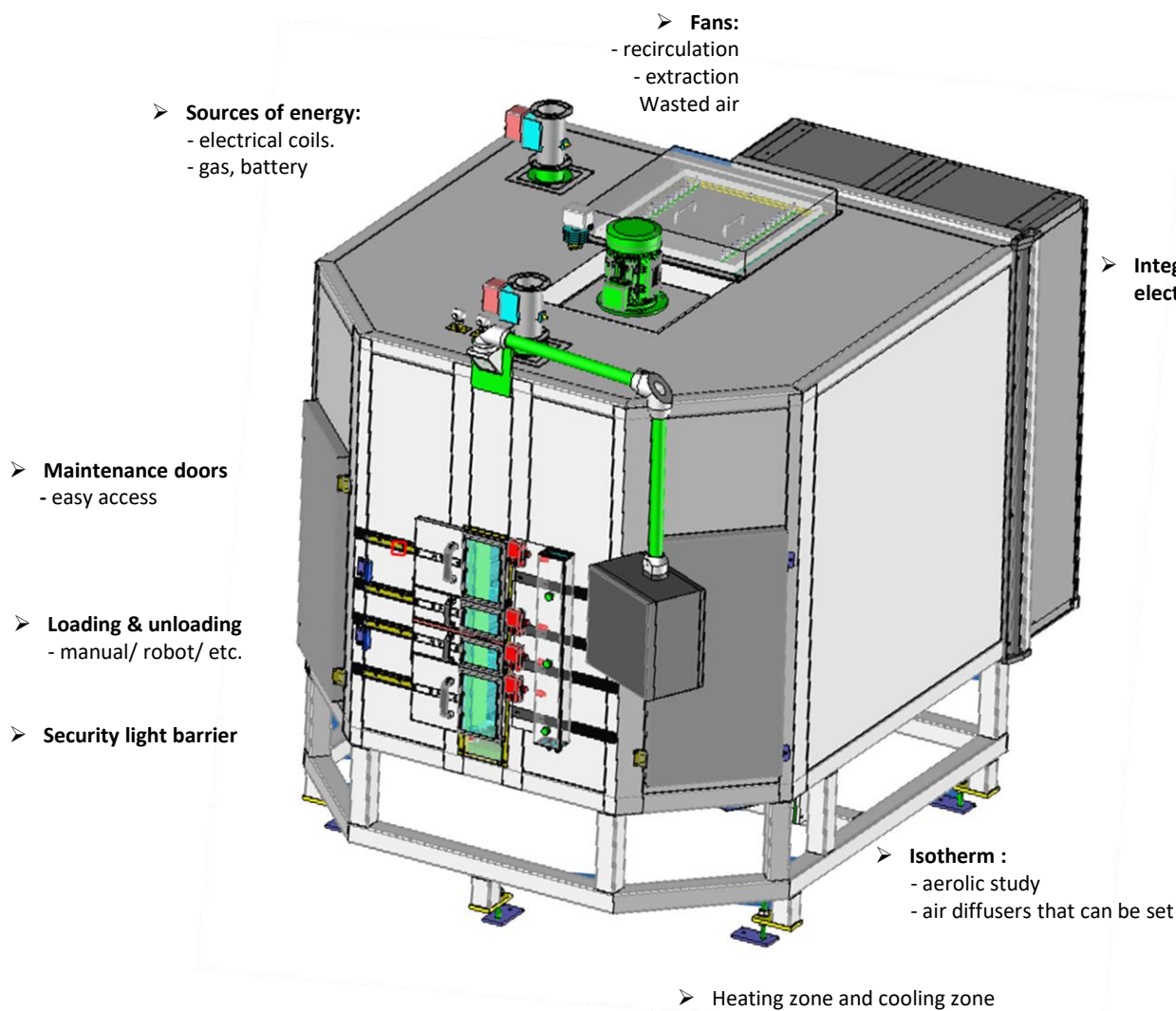

## The advantages:

- ✓ Compact, monobloc;
- ✓ Economical and performant design;
- ✓ Reduced footprint;
- ✓ Easy inline integration;
- ✓ Accessible and mobile
- ✓ Numerous industrial applications.

- **Industrial oven** that integrates a gear mot. turntable, with distinct section to accommodate workparts on one or more levels
  - **Continuous oven**

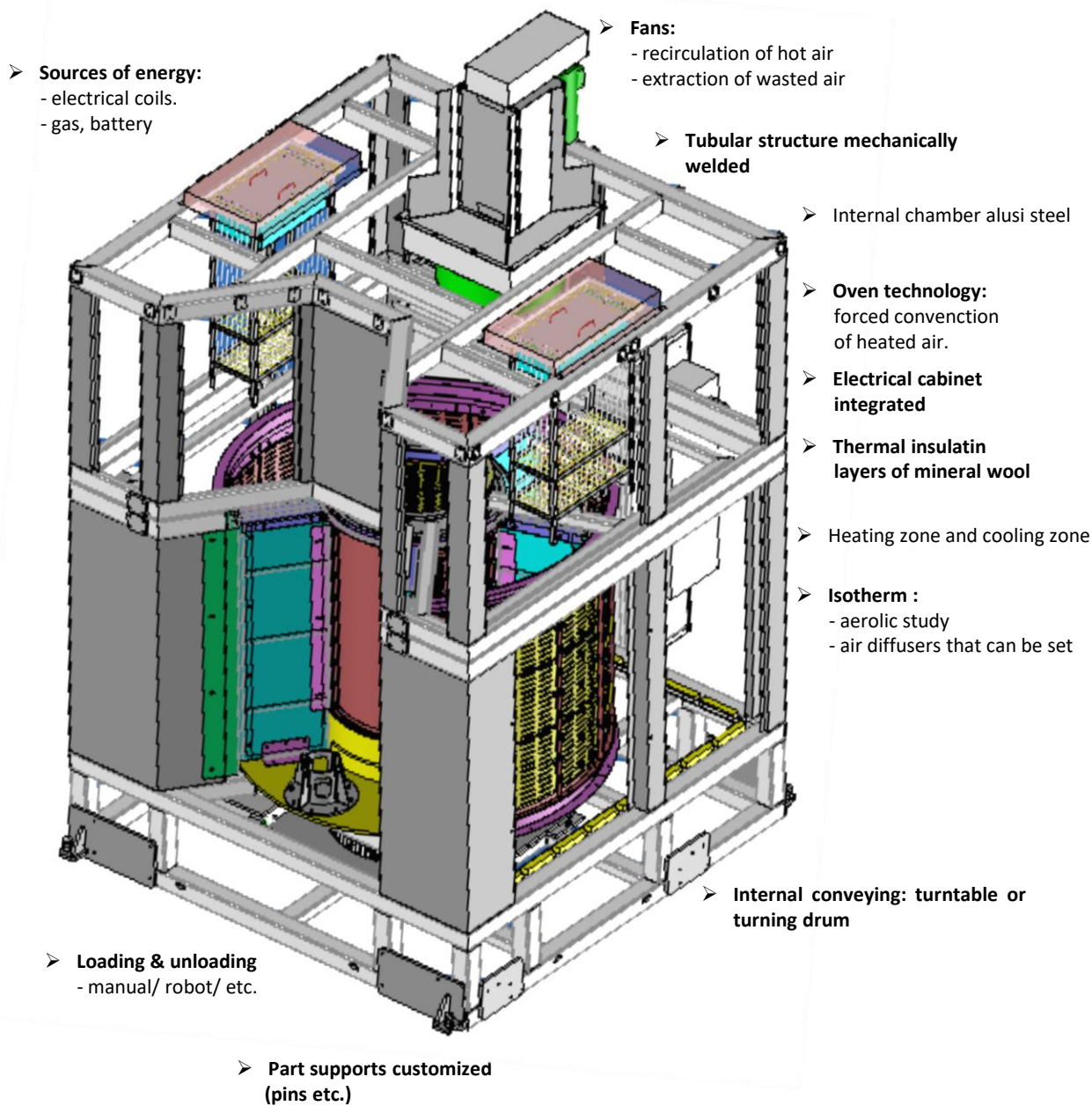



## OTHER EXAMPLES OF TURNTABLE OVENS ADAPTABLES TO A VARIETY OF PROCESS

