

The pros:

- ✓ Compact, monobloc construction;
- ✓ Economical and performant conception;
- ✓ Low footprint;
- ✓ Quick and continuous transfer;
- ✓ Implemented customer's trays; continuous process
- ✓ Numerous applications.

Vertical conveyor oven:

Two chain conveyor equipped with steel corners take in charge the parts deposited on customer's trays.

One chain conveyor transfers the trays to the top of the oven; the second chain conveyor transfers the trays to the bottom.

Change of conveyor via pneumatic horizontal transfer.

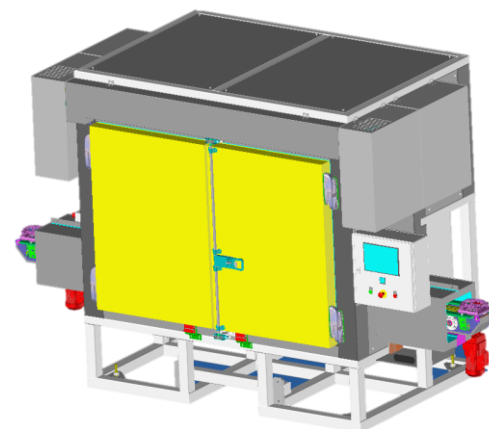

Max. temperature of use
•Temperature maxi. : < 300 °C

Unloading zone

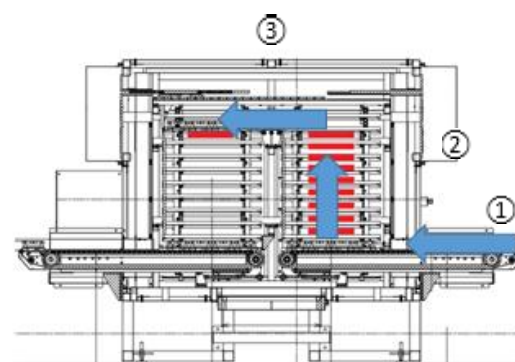
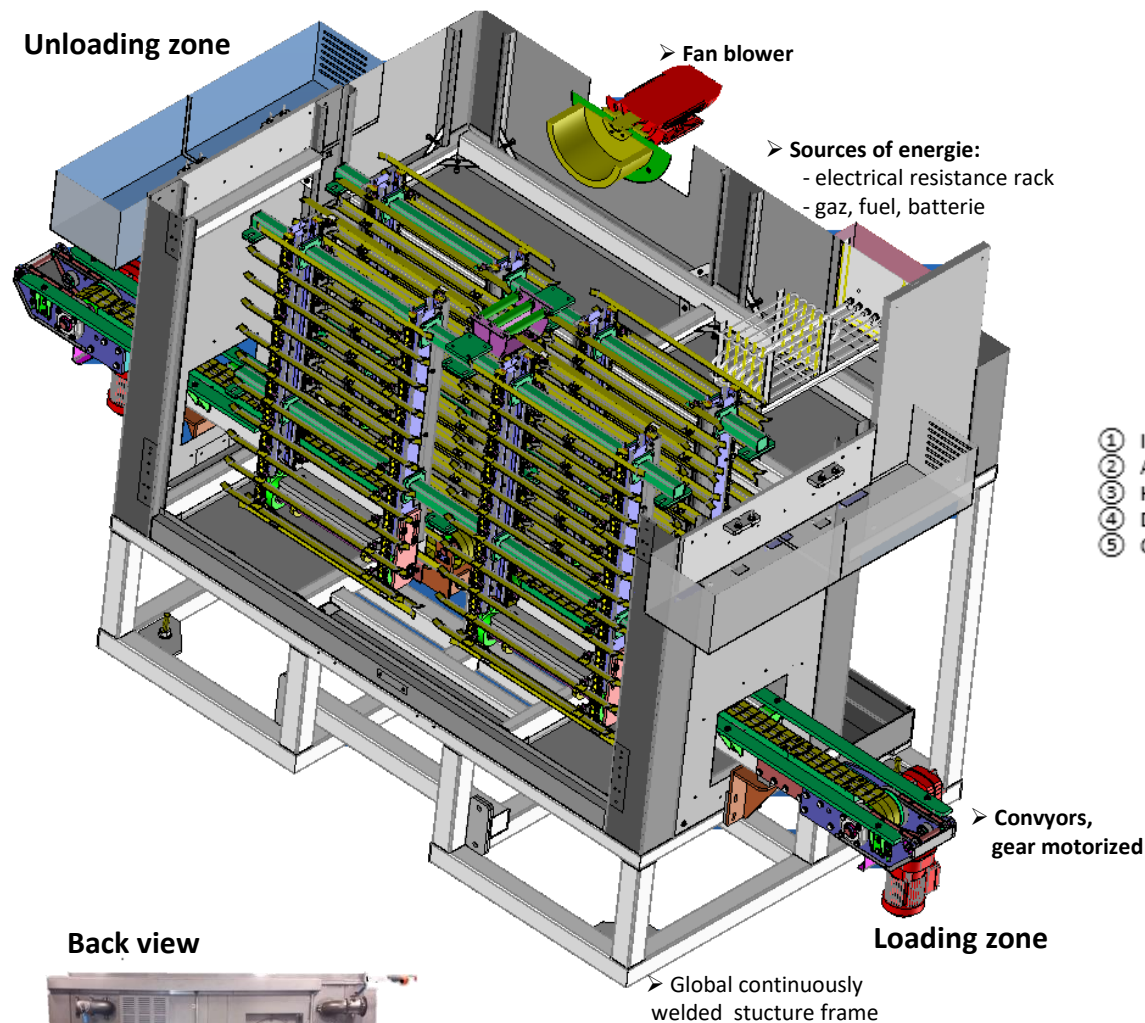

- ① Inlet conveying
- ② Accumulation and lifting up.
- ③ Horizontal transfer on the top
- ④ Descending simultaneous to 2.
- ⑤ Outlet conveying

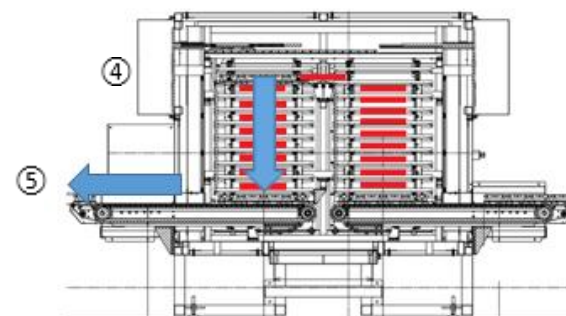
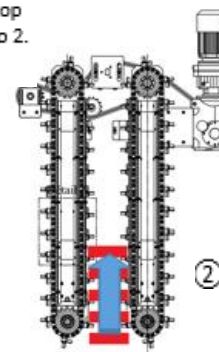

Back view

